

TZ-CLIC SKYLIGHT



DESCRIPTION AND APPLICATIONS

Product

Skylight panel made of **cellular polycarbonate** with **hidden fastening**, **protection from UV light** and **Euroclass B-s1,d0** fire classification.

With a thickness of 30 mm and a useful width of 1,150 mm **it is compatible with any TZ-C panel thickness**, has the same useful width as the panels and follows their modulation. It is also **compatible with all their accessories**.

Applications

Natural lighting in sandwich panel enclosures for industrial and commercial buildings, and sports facilities.



TECHNICAL SPECIFICATIONS

The TZ-CLIC skylight has a **hidden fastening** system consisting of a clamp attached to the fixing screw of the adjacent panel, which avoids the need to drill through the polycarbonate. A flashing profile covers the assembly, thus guaranteeing an **excellent finish** and making the system **leak-proof**.

Intermediate clamps can be incorporated between supports to improve the behaviour of the system under high loads, both pression and suction.

On roofs with TZ-C panels thicker than 30 mm, shims should be installed to support the skylight on the purlins.

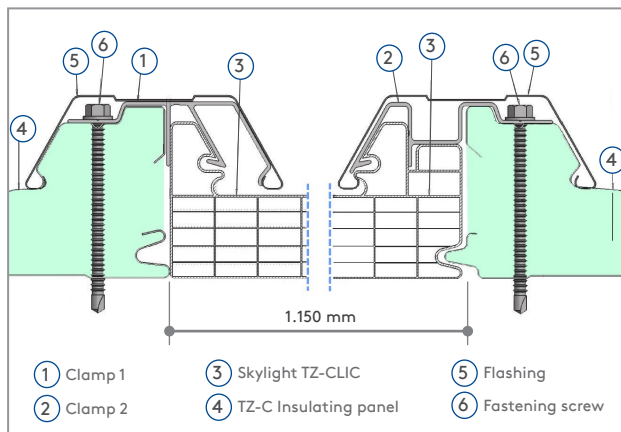

Load table:

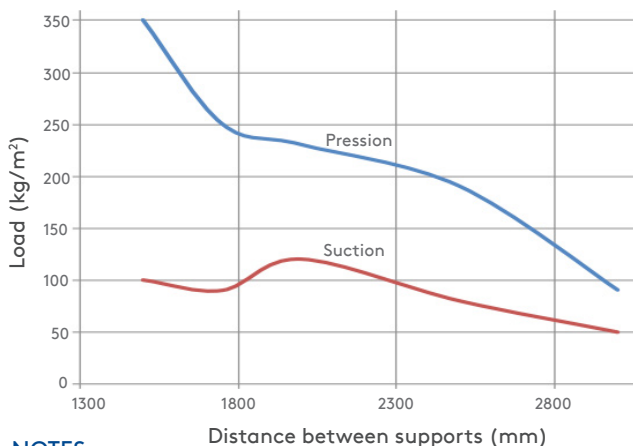

NOTES:

- Anti-slip clamps should be fitted for spans over 1,800 mm
- FS1 security factor
- 1/50 deformation. Minimum slope of 5°
- Chart results for intermediate supports. The initial and final openings must have a distance between supports <80% of the rest of the intermediate spans.
- Do not walk on the skylight

Product data:

Thickness	30 mm
Useful width	1,150 mm
Maximum length	34 m
Structure	6 walls
Standard colour	Light opal
Light transmission	39 %
Solar factor	0.46
UV protection	Exterior face
Linear expansion	0.065 mm/m °C
Thermal insulation	1.25 W/m ² °C
Reaction to fire	B-s1,d0

Teczone Española S.L.U. reserves the right to modify the contents of this document without any prior warning. Every effort has been made to ensure that the content of this publication is accurate, but Teczone Española S.L.U. and its affiliated companies are not responsible for errors or information that may be misleading. Suggestions regarding the final use or application of the products or work methods are merely informative and Teczone Española S.L.U. and its affiliates do not accept any responsibility in this regard.